

# Hi-Heat Enclosure Heaters

---

## Enclosure heaters designed for all conditions.



These units are a necessity when freeze and condensation protection is required. The enclosure heater can be ordered by themselves with an adhesive backing or factory vulcanized to an aluminum plate. The plate will have a flange for easy bolt in assembly. As well, the unit can come with an optional air sensing thermostat in line and bonded to the heater or remote mounted.

### Factory Specifications

Contact factory for specific application questions.

- 120 volt (Contact the factory for alternate voltages)
- Watt density of (5 W/in<sup>2</sup>)

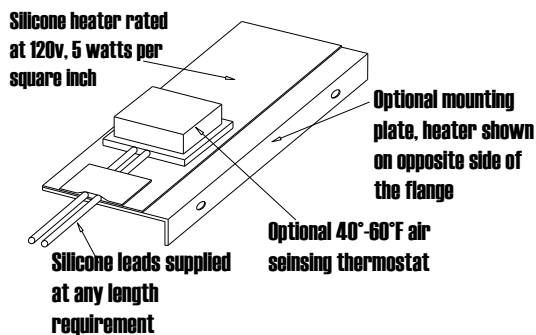

### Applications

Freeze or condensation prevention examples include but are not limited to:

- Car wash coin box
- Traffic signal boxes
- Valve housings
- Enclosures with temperature sensitive components

### Features

- Various mounting options
- Quick delivery
- Safe and reliable
- Custom designs available upon request

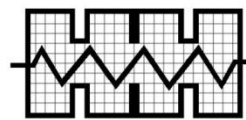

### HI-HEAT IND. INC.

256 Hanover Road  
Lewistown, Montana 59457 USA  
Phone: +1(406)538-7411  
Fax: +1(406)538-3152  
Internet: [www.hiheat.com](http://www.hiheat.com)  
e-mail: [info@hiheat.com](mailto:info@hiheat.com)